

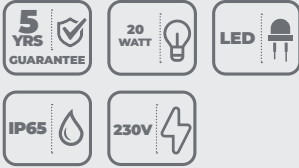

# TITAN COMMANDO KIT

## EMERGENCY SELF TEST KIT



Titan Commando Emergency Self Test Kit utilises rechargeable LiFeP04 battery technology, to deliver a versatile solution. Designed to be used with Commando Pro and CommandoPlus.

### Features

- Pre-wired cables and Carabiner
- Uses advanced technology LiFeP04 batteries
- 5 second test carried out every 7 days
- High output self test emergency kit

### Specification

<b>Material:</b>	Extruded & Die-cast Aluminium
<b>Colour Temperature:</b>	4000K & 6500K
<b>IP Rating:</b>	IP65
<b>IK Rating:</b>	IK10
<b>Working Temperature:</b>	0°C to 50°C
<b>Charge Time:</b>	24 Hours
<b>Included:</b>	Pre-wired cables and Carabiner
<b>Emergency Battery Type:</b>	LiFeP04
<b>Guarantee:</b>	5 Years (Battery 2 years)

### Dimensions

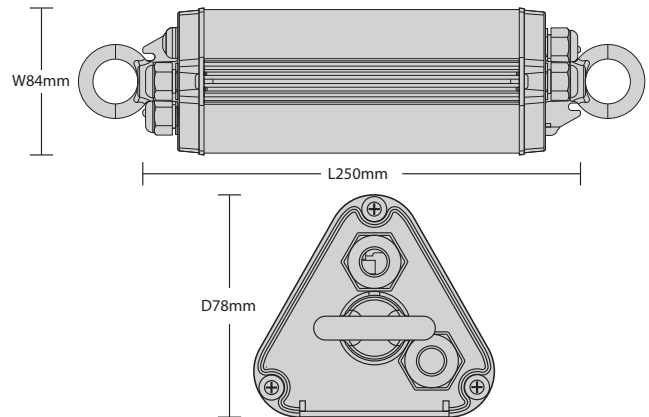

Product Code	Description	Wattage	Emergency Power	DC Output	Net Weight (kg)	Barcodes
TITAN/COMKIT20/ST	Titan Commando Emergency Kit Self Test	20W	15W	200-300VDC (MAX)	1.42	5055807625241



[www.redarrowelectrical.co.uk](http://www.redarrowelectrical.co.uk)